

EDGE LIT



Not all products are qualified on the DLC QPL. To view our DLC qualified products, please consult the DLC Qualified Products List at www.designlights.org/qpl

**** AVAILABLE ****

0% ▶ 100%

Analog
Triac Dimming

0 - 10V
FULL DIMMING

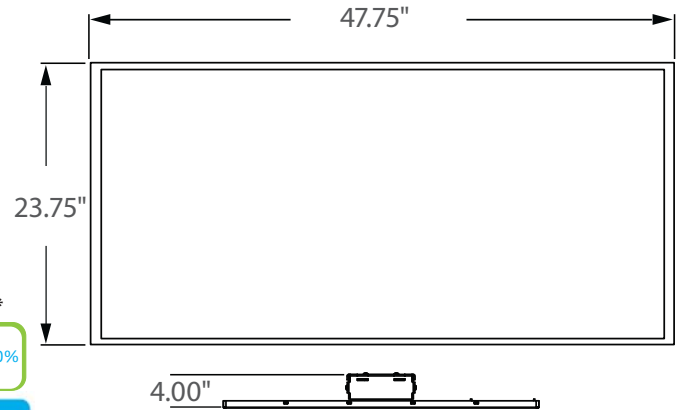

Incredible 75,000 hrs

GENERAL DESCRIPTION

Neptun's high performance Edge Lit LED 2 x 4 drop in panels combine architectural form and versatility to make it an excellent choice for new construction or retrofit applications. The 52 series panels are offered in a variety of color temperatures for flexibility in all types of applications. The edge lit design produces an evenly illuminated glow. Very low temperature operation saves on HVAC costs and long life greatly reduces maintenance costs. Easily installs into most commonly used T-Bar grids.

APPLICATION

- Office Lighting
- School Lighting
- Healthcare Lighting

STRUCTURE, MATERIALS, & FEATURES

- Heat sink white aluminum frame for excellent heat dissipation.
- Aluminum backing for excellent thermal management.
- Polyester powder coated frame with white finish.
- Slim, state of the art, low profile design.
- Correlated Color Temperatures of 3500°K, 4100°K, & 5000°K.
- High Output LED's.
- High power factor, low THD driver.
- InstantON flicker-free Cold Start and Hot Re-Start.
- Up to 15 years Maintenance free operation.
- 5 Year Warranty on complete fixture. (LED's, Driver, & Housing)
- **Optional:** Analog/Triac Dimming, 0-10V Dimming, Remote Monitoring, Emergency Battery Backup

ORDERING INFORMATION

Sample Number: LED-52050-UNV-0-10VDIM-841
 Custom options and accessories available. Please consult factory

Source	Series	Wattage	Driver System	Options	Color Temp.
LED = LED	52 = 2 x 2 panel	050 = 50 W 060 = 60 W	UNV-0-10VDIM = 120-277VAC w/ 0-10V Dimming Driver 120V-ADIM = 120V Analog/Triac Dimming	EM-BB15 = Emergency Battery Backup - Used w/ 40w model (10w battery backup - 90min.) * Not available in 60w Unit SFM = Surface Mount Kit	835 = 3500°K 841 = 4100°K 850 = 5000°K



PRODUCT INFORMATION

Model No.	Description	Rated Watts	Input Watts	Delivered Lumens	Universal Line Voltage (VAC)	Max Line Current (Amp) @ 120 - 277	THD	Power Factor	Weight
LED-52050-UNV	2x4 Ceiling Panel	50	51	5,500	120-277	0.43 - 0.18	<20%	>0.90	15 lbs
LED-52060-UNV	2x4 Ceiling Panel	60	61	6,600	120-277	0.52 - 0.22	<20%	>0.90	15 lbs

SPECIFICATIONS

- LED Driver Constant Current
- Power Supply 350mA
- Driver UL Rating Class 1
- Start Method InstantON
- Hot Re-start InstantON
- Input Line Voltage 120-277 VAC
- Input Line Frequency 50/60 Hz
- Ballast Off-State Draw 0 Watts
- Sound Rating Class A
- Projected (L70) @ 25°C > 75,000 hrs.
- Color Temperature 3,500°K, 4,100°K, 5,000°K
- Color Rendering Index (CRI) > 80
- Minimum Starting Temperature -10°C
- Maximum Starting Temperature 40°C
- Lumens per Watt > 100
- Shock / Vibration Resistant Yes
- Power Factor > 0.90
- Total Harmonic Distortion < 20%
- Inrush Current Peak < 10 Amp
- FCC Compliance Part 15, Subp. C
- IP Rating IP43
- Warranty 5 Year

MOUNTING OPTIONS

T-BAR GRID SYSTEM (Standard)

- Easy drop in installation in to standard 1x4 t-bar grid system.
- Power cord whip provided.

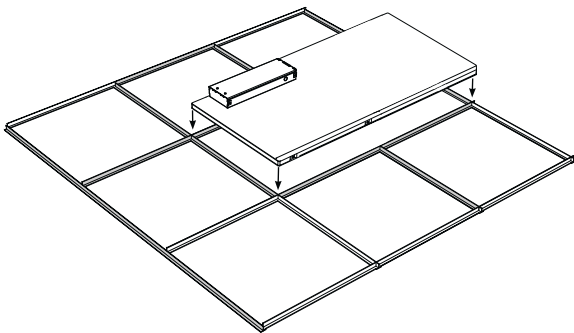

SURFACE MOUNT KIT (SFM)

