

## Solar Powered SL10 LED Aviation/Navigation Warning Light



**Advantages:**

- Free maintenance.
- ON/OFF button.
- Very portable, easy transportation and installations.
- Autonomy more than 7 days without sunshine.
- LED low power consumption only 1.5Watts average.

**Electrical Features:**

- Lamp:50,000 hours high quality.
- FPM:customized before order.
- Color:Red,blue,green,yellow,white.
- Autonomy: Flash 10 days; Fixed 7 days.
- Light intensity: >30cd nighttime.
- Output:360° horizontal; >10° vertical.
- Photo sensor:100Lux

**Solar Features:**

- Battery: 3.2V/1400MAH lithium-ion battery.
- Panels: 1×monocrystalline silicon panels(>18% efficiency) on top.

**Physical Features:**

- Housing: polycarbonate.
- Overall size:  $\phi 17.5\text{cm} \times 15.5\text{cm} (\phi 6.8'' \times 6.1'')$ .
- Mounting size: 3×6mm Holes.
- IP rating: IP68.
- Weight: 1KG.
- Operating: -40°C to 75 °C.
- Wind speed: 80m/s.

**Mounting:**

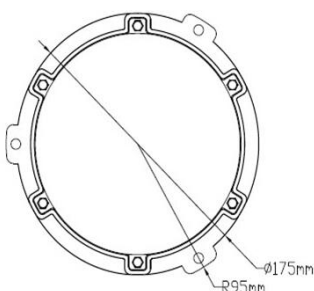
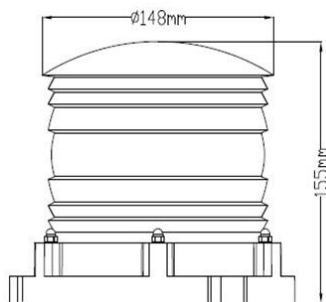

**Obstruction&Traffic:**

- Telecom
- Cranes
- Buildings
- Barricade
- Other obstacles

**Airfield:**

- Airstrip
- Taxiway edge
- Heliport edge

**Marine:**

- Port
- Vessel
- Yacht

**Order Code:**

| Type | Work      | Flashes | Output                 | Mounting Option            |
|------|-----------|---------|------------------------|----------------------------|
| SL10 | S: Steady | 15      | Red                    | 00 <sup>1</sup>            |
|      | F: Flash  | 30      | Green                  | Magnetic Base <sup>2</sup> |
|      |           | 60      | Blue                   |                            |
|      |           | 80      | White                  |                            |
|      |           | 120     | Yellow                 |                            |
|      |           |         | 135° beam <sup>3</sup> |                            |

<sup>1</sup> The light is standard 3×6mm holes installations.

<sup>2</sup> The light shall be mounted by magnetic base.

<sup>3</sup> 135° beam: the light can be customized to produce a 135° output beam of single color.

**Package:**

- 60×40×20CM, 6PCS/CTN.
- 6.4KG/CTN Gross Weight.

